

BACK BOX



COM VENTILAÇÃO



Opção base.



Opção base Slim.



Opção base Duo.

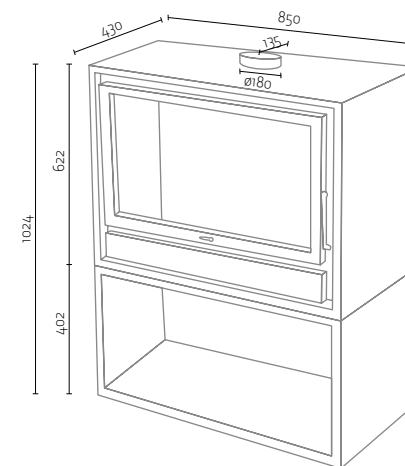

CARACTERÍSTICAS

CARACTERÍSTICAS	BACK BOX
POTÊNCIA DE UTILIZAÇÃO (kW)	6,4 - 11,8
CONSUMO DE LENHA (kg/hora)	1,5 - 2,8
EMISSÕES DE CO (a 13% oxigénio)	0,37
EMISSÕES DE CO ₂ (%)	9,7
PESO (kg)	140
DIÂMETRO DA CHAMINÉ (em mm)	180
POTÊNCIA NOMINAL (kW)	11,0

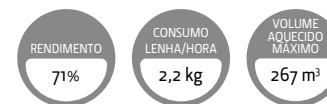

CLASSE DE EFICIÊNCIA

